

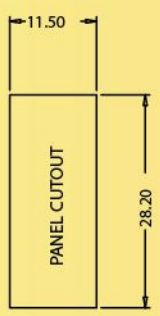

# PRIME COMPONENTS

"Connections for life"

## ROCKER SWITCH SERIES PRS 11



PRS 11 101

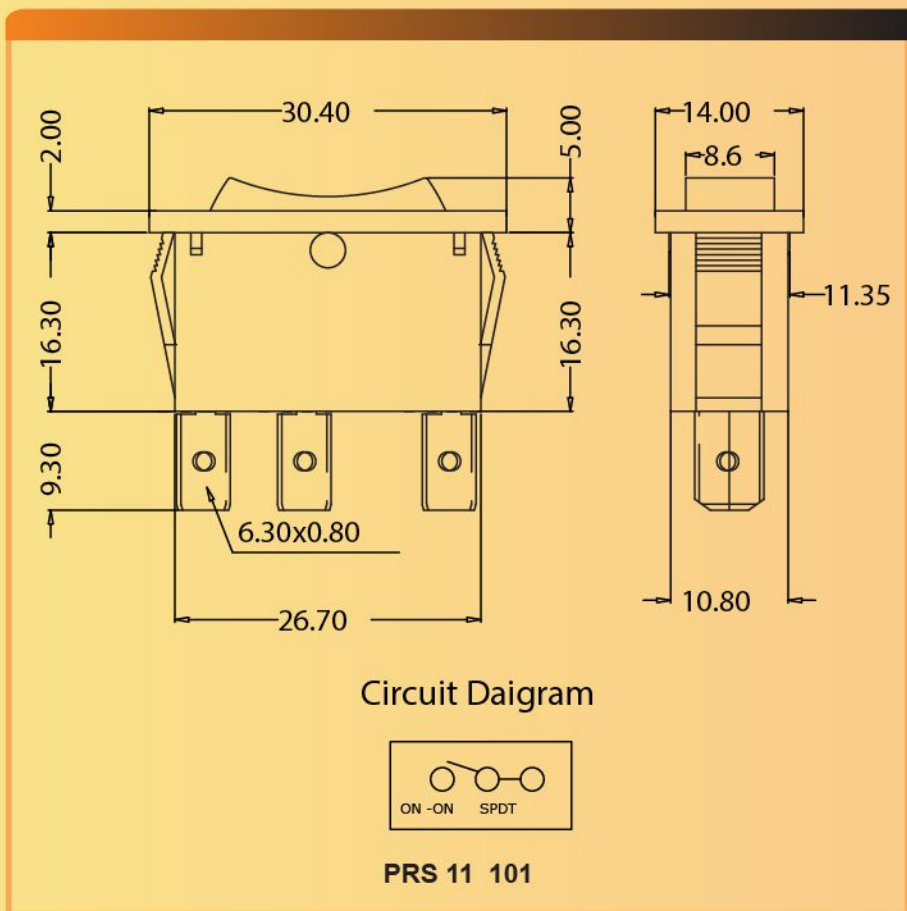

### TECHNICAL SPECIFICATION

Note: All Dimension are in mm

PARAMETERS	SERIES	PRS 11-6A	PRS 11-16A
Switch Type		Non-Illuminated	Non-Illuminated
Model		SPDT	SPDT
Current Rating		6A,250V AC/9A 125V AC	16A,250V AC/20A 125V AC
Insulation Resistance		>20 M Ohm	>20 M Ohm
Dielectric Strength		>3KV	>3KV
contact Resistance		<10M Ohms mix.	<10M Ohms mix.
Terminal Style		Fast On 6.3x0.80	Fast On 6.3x0.80
Permissible Temp. for Soldering		270°, 5 sec. Max.	270°, 5 sec. Max.
Moulded Material ( Housing)		PA	PA
Moulded Material ( Rocker)		PA	PA
Center Terminal		Brass (Tin plated)	Brass (Tin plated)
Side Terminal		Brass(Tin plated)	Brass(Tin plated)
Centre Contact		Brass(Tin plated)	Brass(Tin plated)
Fixing		Sanp Mounting	Sanp Mounting
Electrical Endurance		>10,000 Cycles	>10,000 Cycles
Sp. colour available on MOQ.			

### Series Also Includes...



Off / Works : 830, GIDC Estate, Makarpura, Vadodara - 390010

[www.primecomponents.net](http://www.primecomponents.net)

+91-265-6642566/6670078, +91 9687676700

[sales@primecomponents.net](mailto:sales@primecomponents.net)